

legend	
JXX	JST-PH
JXX	JST-VH
JXX	JST-EH
JXX	Dubox
JXX	D-Sub
JXX	μ-Match
JXX	Stiftwanne
JXX	USB
JXX	AMP-Modu 50
JXX	ZIF
JXX	JST-ZH
JXX	Phoenix

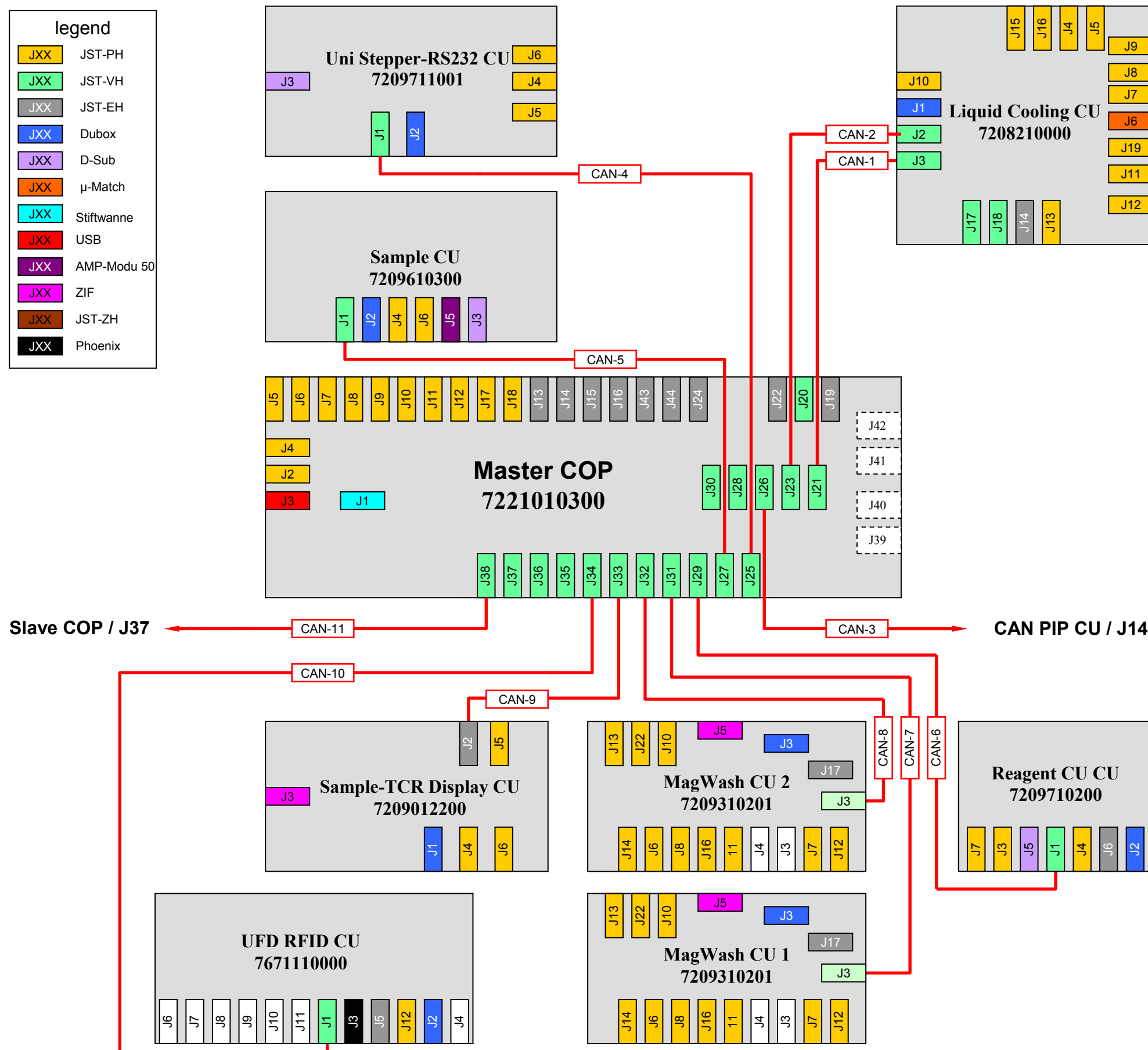

No.	Cable Title	PPS
CAN-1	CC/PWR-CAN,JST-VH,8POL,2300MM	2710000240
CAN-2	CC/PWR-CAN,JST-VH,8POL,2300MM	2710000240
CAN-3	CC/PWR-CAN,JST-VH,8POL,600MM	2710000229
CAN-4	CABLE, POWER-CAN, 6 PIN, 2000MM	2710000243
CAN-5	CC/PWR-CAN,JST-VH,6POL,1500MM	2710000526
CAN-6	CC/PWR-CAN,JST-VH,6POL,1100MM	2710000525
CAN-7	CC/PWR-CAN,JST-VH,6POL,600MM	2710000257
CAN-8	CC/PWR-CAN,JST-VH,6POL,600MM	2710000257
CAN-9	CC/COP L2<>FRONTCOVER	7221040503
CAN-10	CC/PWR-CAN,JST-VH,6POL,3400MM	2710000527
CAN-11	CC/COP<>COP-EXTENSION,2100MM	7209040103
CAN-12	FFC,1X20,1140MM,RASTER 1.27MM	2710000354
CAN-13	FFC,1X12,920MM,RASTER 1.27MM	2710000155
CAN-14	FFC-ZIF,1X8,348MM,RM1.0,0.65,P7	2700000402
CAN-15	FFC,1X20,1140MM,RASTER 1.27MM	2710000354
CAN-16	FFC,1X12,920MM,RASTER 1.27MM	2710000155
CAN-17	FFC-ZIF,1X8,262MM,RM1.0,0.65,P7	2700000401
CAN-18	CC/PWR-CAN,JST-VH,8POL,1100MM	2710000219
CAN-19	FFC,1X10,1050MM,RASTER 1.27MM	2710000350
CAN-20	FFC,1X10,500MM,RASTER 1.27MM	2710000450
CAN-21	CC/PWR-CAN,JST-VH,8POL,1500MM	2710000220
CAN-22	CC/POWER-CAN,8POL,1200MM	7221040800
CAN-23	CC/PWR-CAN,JST-VH,8POL,1000MM	2710000218
CAN-24	CC/PWR-CAN,JST-VH,8POL,3200MM	2710000159
CAN-25	CC/PWR-CAN,JST-VH,6POL,2X300MM	2710000256
CAN-26	CC/SAMPLE MODULE<>COP	7202842600
CAN-27	CC/MEASURE&WASHER-PUMP<>COP	7202842700
CAN-28	CC/SAMPLE MODULE<>COP	7202842600
CAN-29	CC/CABINET CU<>COP	7221041600
CAN-30	CC/CABINET CU<>COP	7221041600
CAN-31	CC/PWR-CAN,JST-VH,6POL,700MM,KD	2710000531
CAN-32	CC/PWR-CAN,JST-VH,6POL,700MM,KD	2710000531
CAN-33	CC/PWR-CAN,JST-VH,6POL,500MM,KD	2710000530
CAN-34	CC/PWR-CAN,JST-VH,6POL,500MM,KD	2710000530
CAN-35	CC/PWR-CAN,JST-VH,6POL,500MM,KD	2710000530

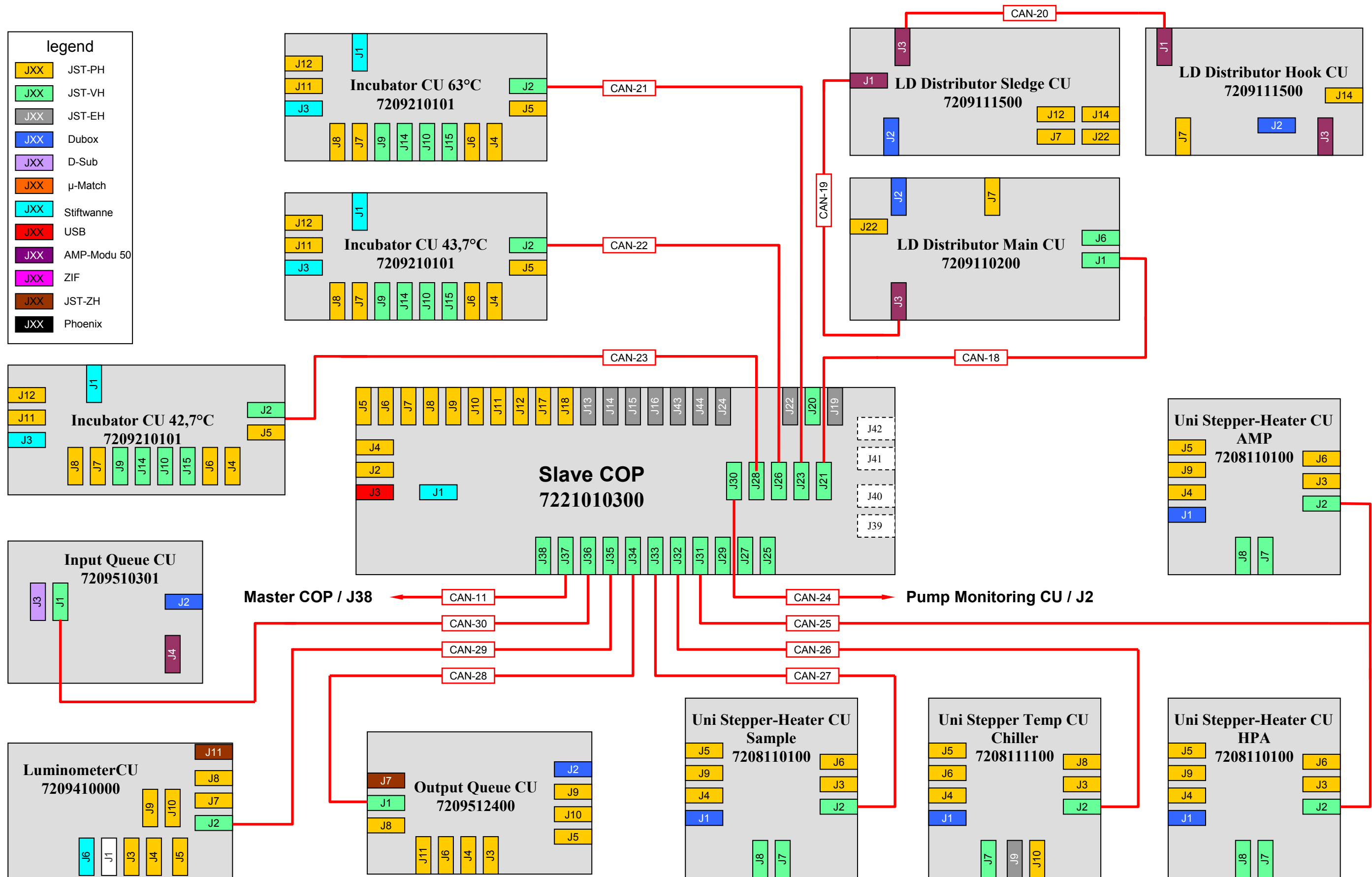

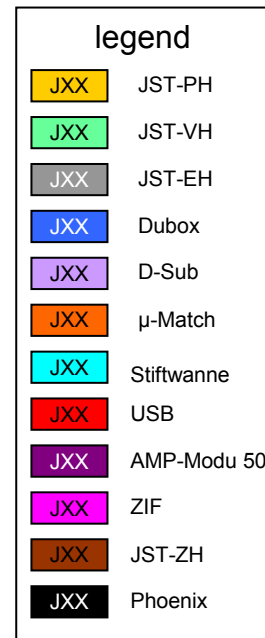

legend	
JXX	JST-PH
JXX	JST-VH
JXX	JST-EH
JXX	Dubox
JXX	D-Sub
JXX	μ-Match
JXX	Stiftwanne
JXX	USB
JXX	AMP-Modu 50
JXX	ZIF
JXX	JST-ZH
JXX	Phoenix

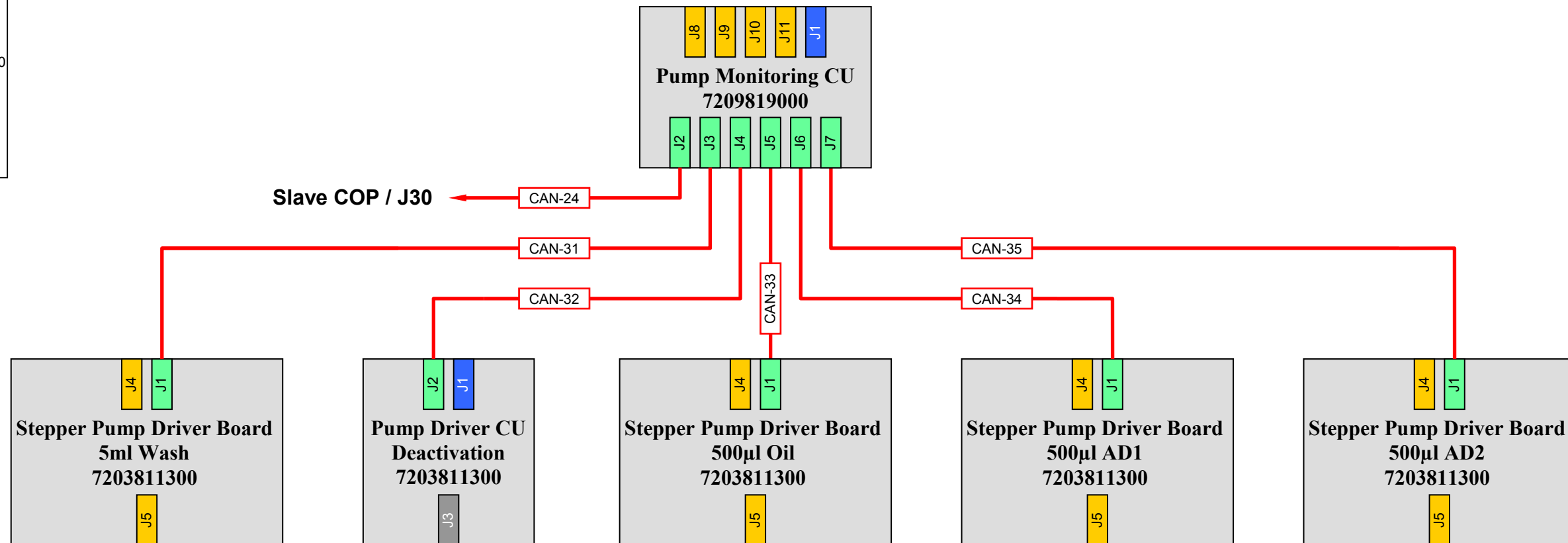

legend	
JXX	JST-PH
JXX	JST-VH
JXX	JST-EH
JXX	Dubox
JXX	D-Sub
JXX	μ-Match
JXX	Stiftwanne
JXX	USB
JXX	AMP-Modu 50
JXX	ZIF
JXX	JST-ZH
JXX	Phoenix

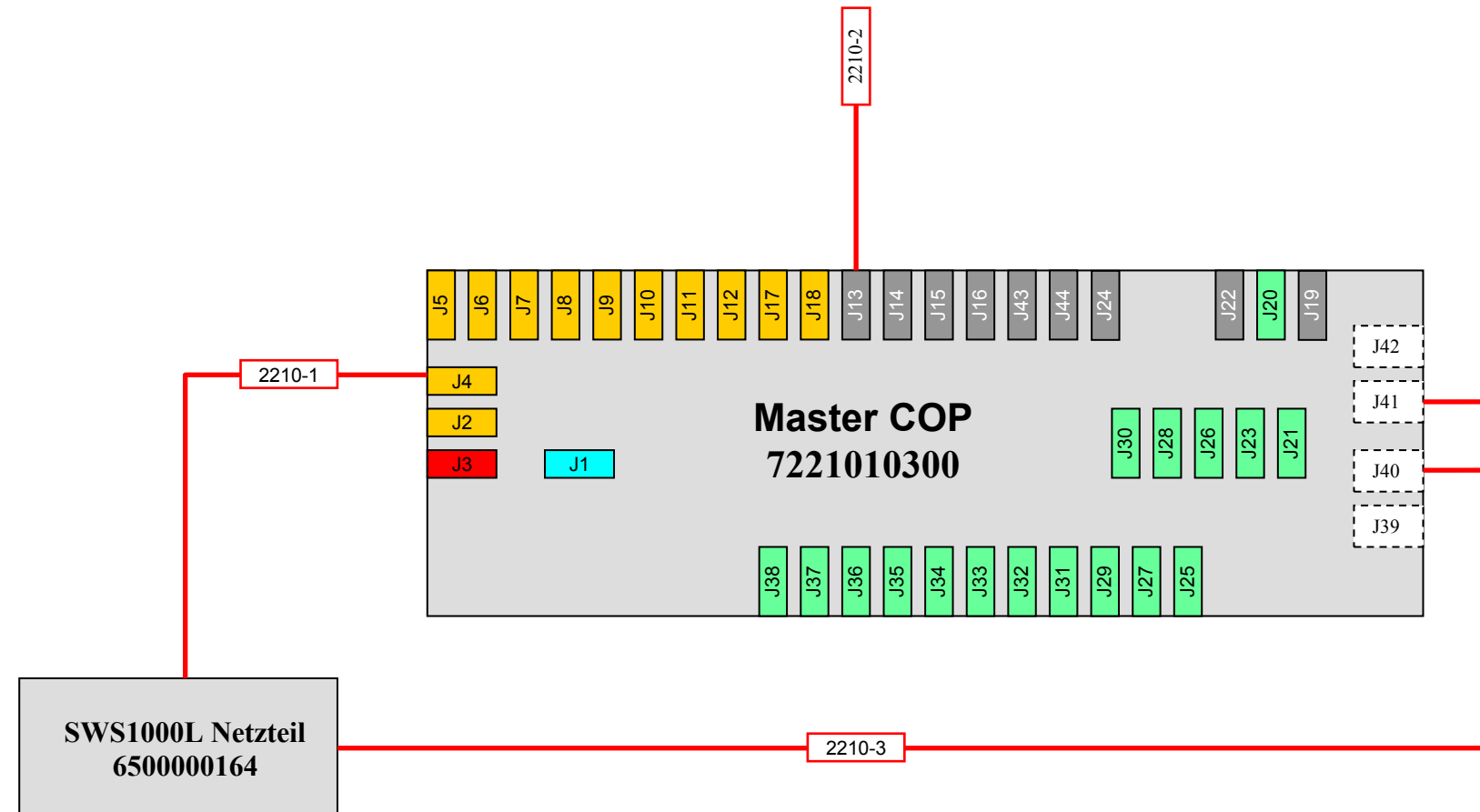

No.	Cable Title	PPS
2210-1	CC/COP<>SHUTDOWN NETZTEIL,1040MM	7209043400
2210-2	DUAL-FAN/DC,EE92252B1<>EH,1320MM	10100000304
2210-3	CC/24V PWR,RK<>RK,AWG12,850MM	7209043200
2210-4	CC/24V PWR,RK<>RK,AWG12,1250MM	7209043300

legend	
JXX	JST-PH
JXX	JST-VH
JXX	JST-EH
JXX	Dubox
JXX	D-Sub
JXX	μ-Match
JXX	Stiftwanne
JXX	USB
JXX	AMP-Modu 50
JXX	ZIF
JXX	JST-ZH
JXX	Phoenix

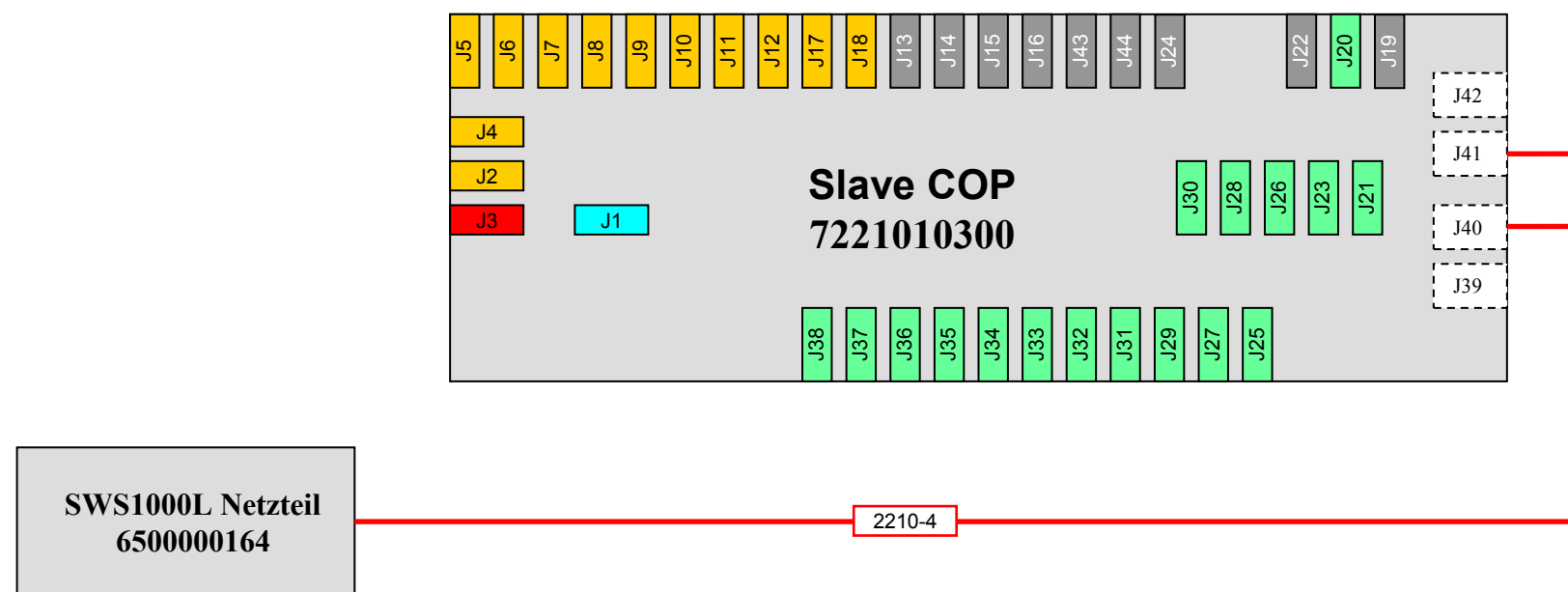

legend	
JXX	JST-PH
JXX	JST-VH
JXX	JST-EH
JXX	Dubox
JXX	D-Sub
JXX	μ-Match
JXX	Stiftwanne
JXX	USB
JXX	AMP-Modu 50
JXX	ZIF
JXX	JST-ZH
JXX	Phoenix

**AMP Load Station**

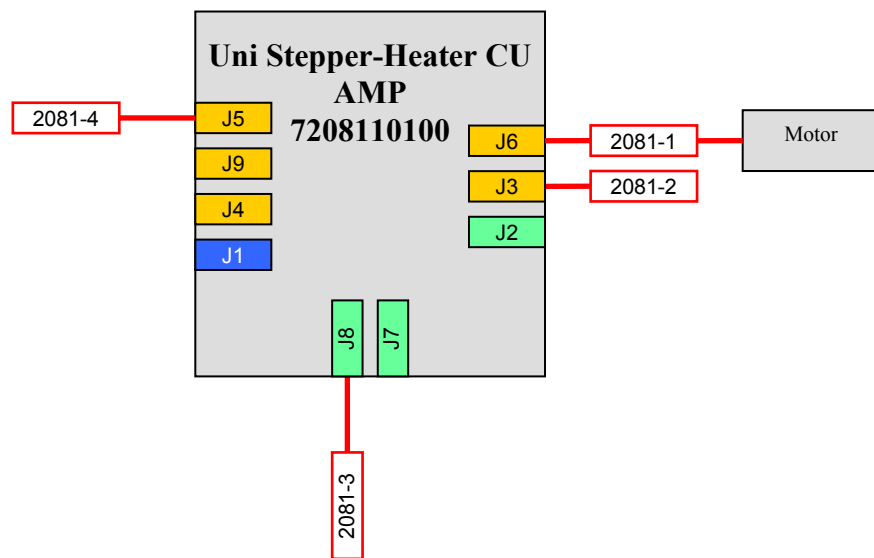

No.	Cable Title	PPS
2081-1	STEPPER-MOTOR,AWG26,150MM,PH,NL,SS	2710000202
2081-2	OPB933W51,PH,120MM,NATUR	6810000180
2081-3	120X95MM,24V,2X12W,SK,HEIZFOLIE	2000000030
2081-4	NTC,PH,110MM,NL	6810000154

**HPA Load Station**

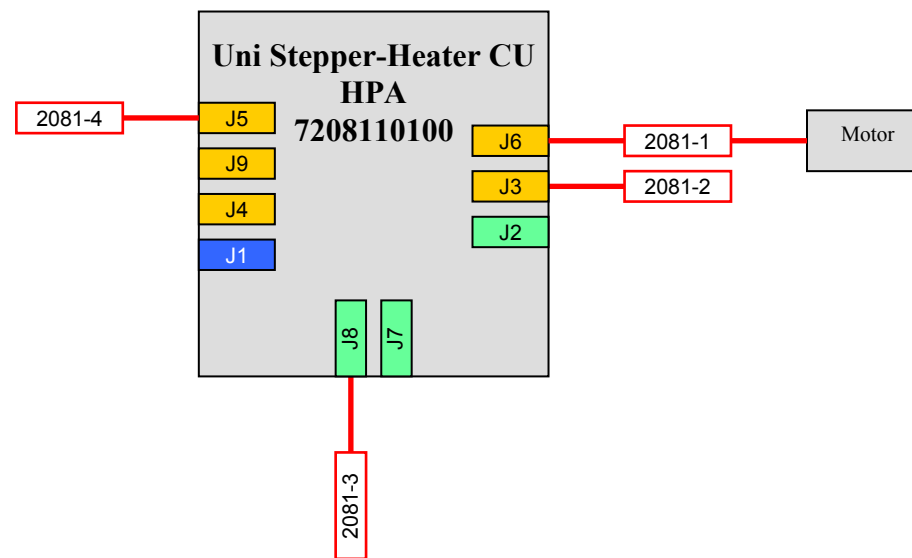

No.	Cable Title	PPS
2081-1	STEPPER-MOTOR,AWG26,150MM,PH,NL,SS	2710000202
2081-2	OPB933W51,PH,120MM,NATUR	6810000180
2081-3	120X95MM,24V,2X12W,SK,HEIZFOLIE	2000000030
2081-4	NTC,PH,110MM,NL	6810000154

**Sample Load Station**

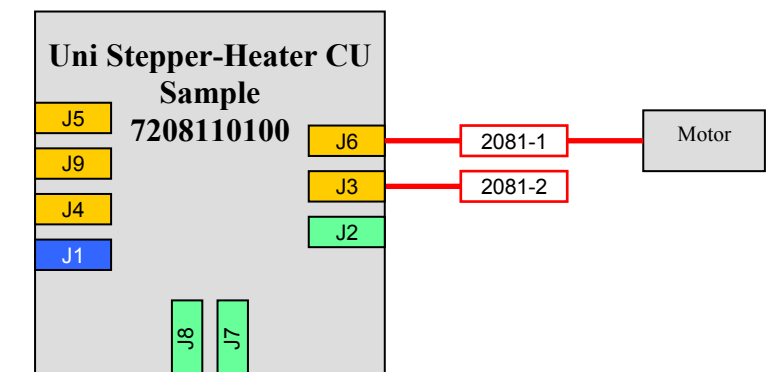

No.	Cable Title	PPS
2081-1	STEPPER-MOTOR,AWG26,150MM,PH,NL,SS	2710000202
2081-2	OPB933W51,PH,120MM,NATUR	6810000180

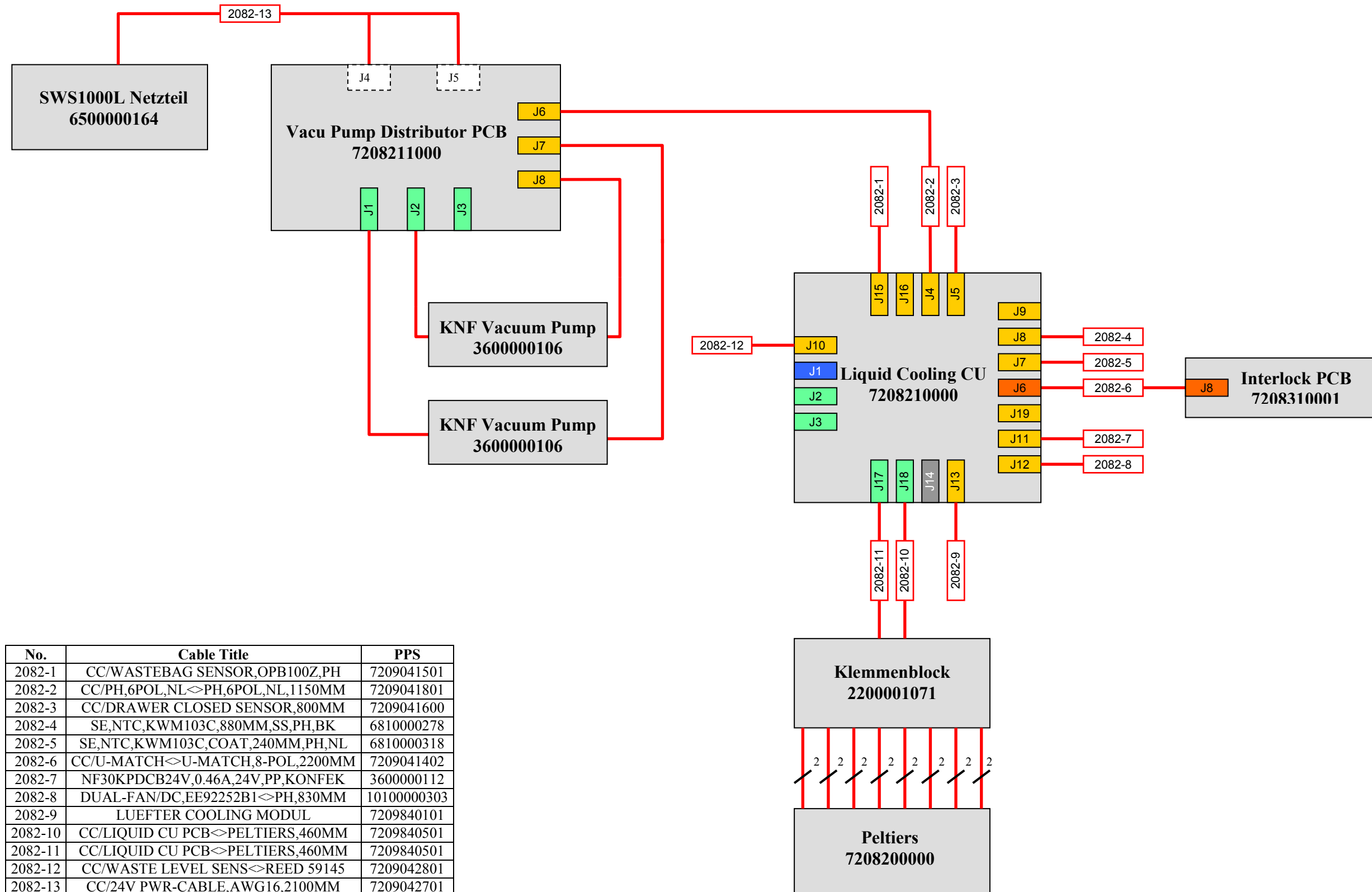

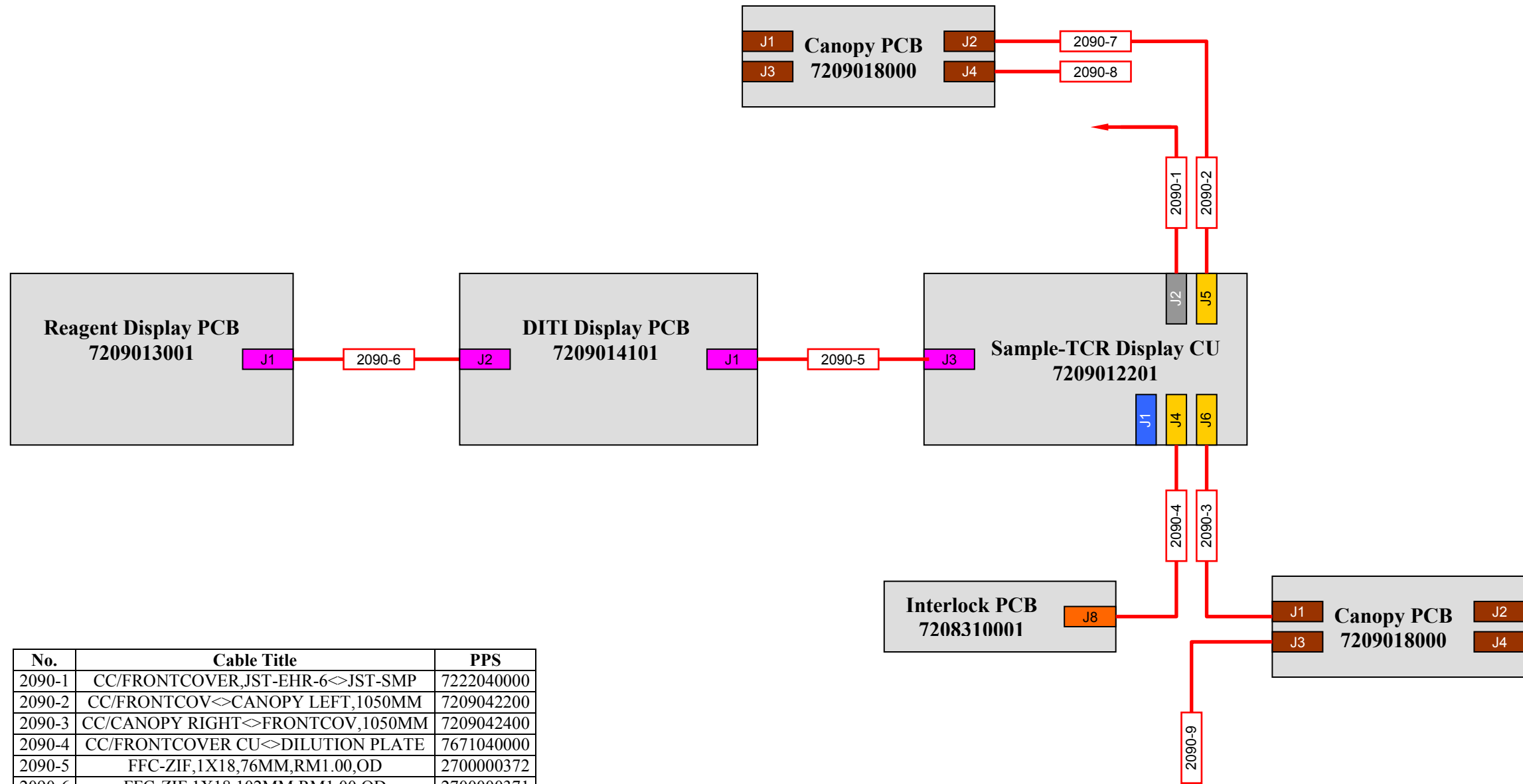

No.	Cable Title	PPS
2090-1	CC/FRONTCOVER,JST-EHR-6<>JST-SMP	7222040000
2090-2	CC/FRONTCOV<>CANOPY LEFT,1050MM	7209042200
2090-3	CC/CANOPY RIGHT<>FRONTCOV,1050MM	7209042400
2090-4	CC/FRONTCOVER CU<>DILUTION PLATE	7671040000
2090-5	FFC-ZIF,1X18,76MM,RM1.00,OD	2700000372
2090-6	FFC-ZIF,1X18,102MM,RM1.00,OD	2700000371
2090-7	CC/CANOPY LEFT<>FRONTCOV,810MM	7209042300
2090-8	SE,SW,ASQ10610J,ZH,2POL,240MM	7209042000
2090-9	SE,SW,ASQ10610J,ZH,2POL,240MM	7209042000

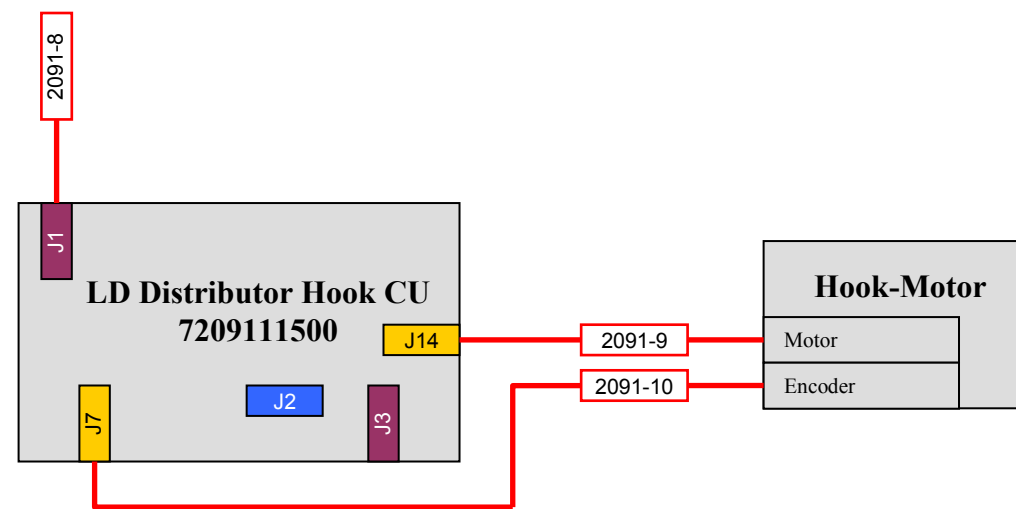
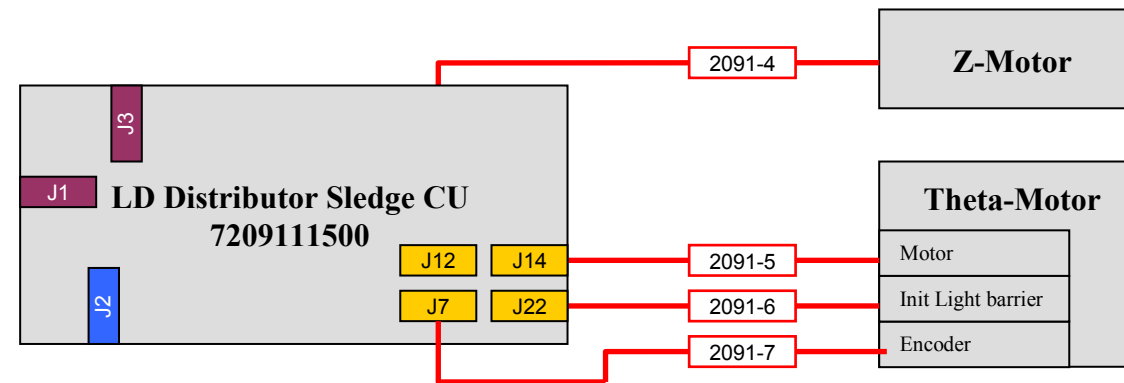
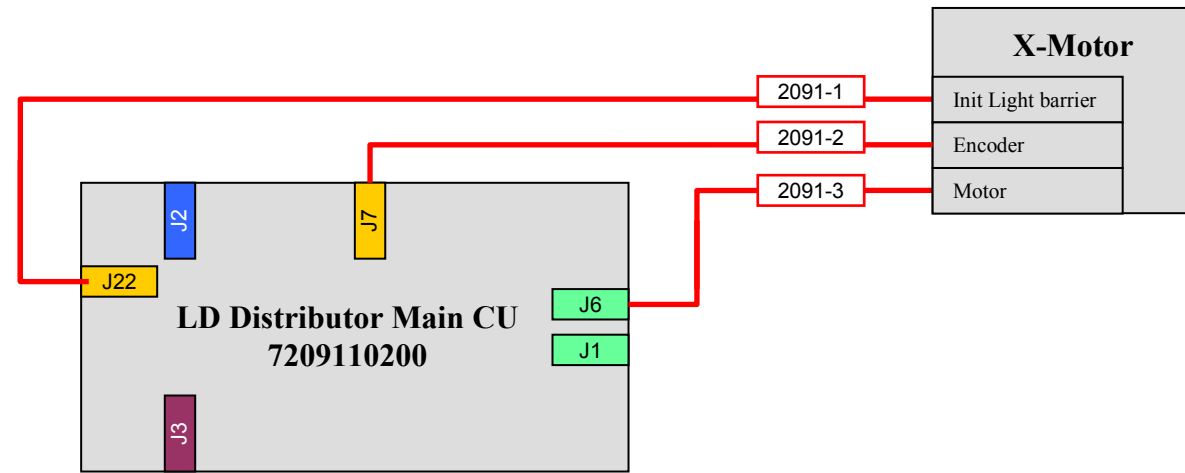

No.	Cable Title	PPS
2091-1	OPB912W55<>JST-PH,200MM,NL	6810000200
2091-2	CC/ENCODER,MOLEX<>JST-PH,200MM,NL	2710000198
2091-3	CC/STEPPER<>JST-VH,300MM	2710000195
2090-4	CC/KH39GM2-X08<>JST-PH,180MM,RD	2710000196
2091-5	CC/STEPPER<>JST-PH,100MM,NL	2710000197
2091-6	OPB912W55<>JST-PH,150MM,NL	6810000171
2091-7	CC/ENCODER,MOLEX<>JST-PH,100MM,NL	2710000199
2091-8	FFC,1X8,262MM,RM 1.00MM,GELOCHT	2710000514
2091-9	CC/STEPPER<>JST-PH,100MM,NL	2710000197
2091-10	CC/ENCODER,MOLEX<>JST-PH,100MM,NL	2710000199

Incubator

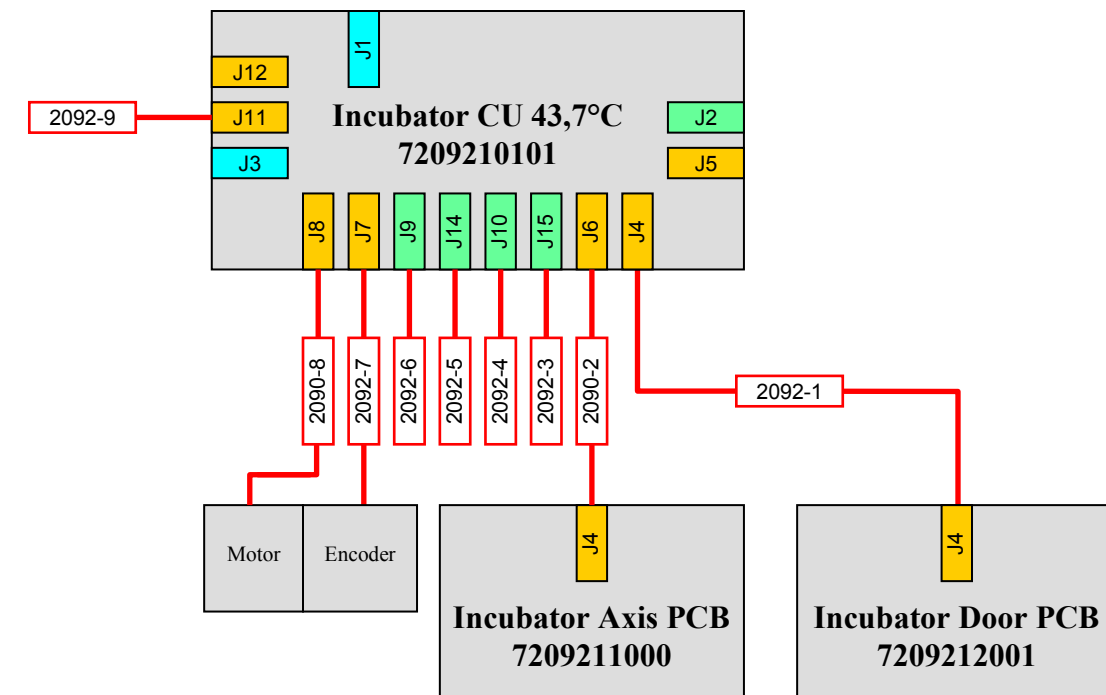
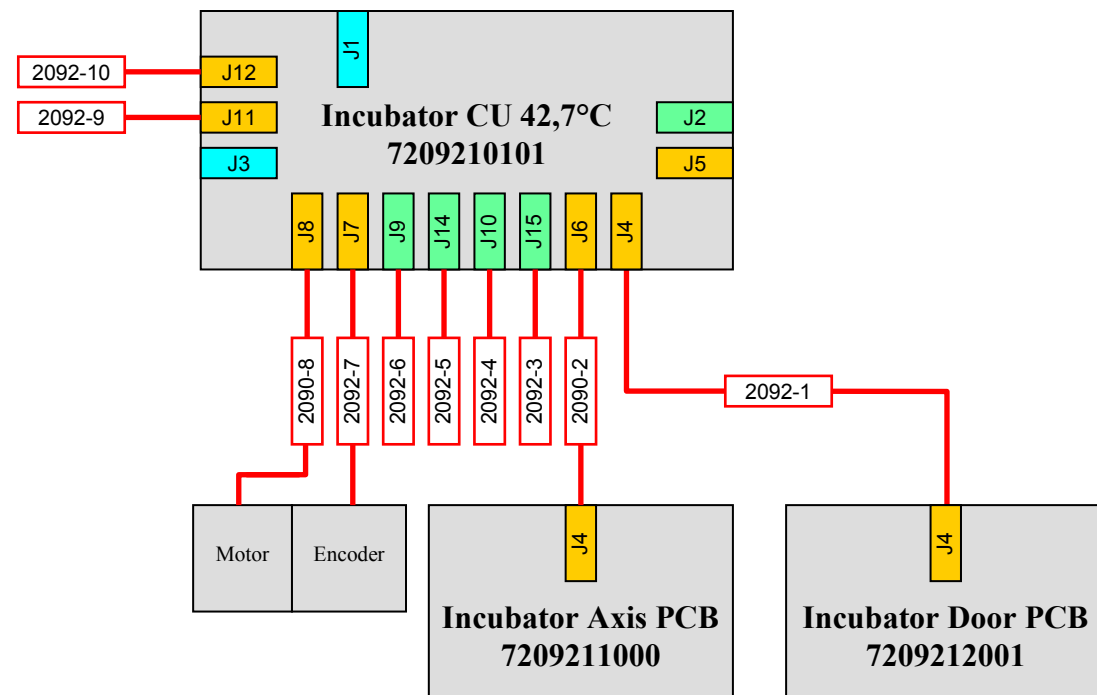

No.	Cable Title	PPS
2092-1	CC/INCUBATOR CU PCB<->DOOR PCB	7209240800
2092-2	CC/INCUBATOR CU PCB<->AXIS PCB	7209240900
2092-3	CC/JUMPER<->VH,2POL	7209241100
2092-4	D259MM,24V,2X35W,SK,HEIZF.THERM.	2000000033
2092-5	CC/JUMPER<->VH,2POL	7209241100
2092-6	846X91MM,24V,2X35W,SK,HEIZFOLIE	2000000031
2092-7	CC/ENCODER,MOLEX<->JST,200MM,YELLOW	2710000189
2092-8	STEPPER-MOTOR2,AWG26,150MM,PH,NL	2710000215
2092-9	CC/LUEFTER,6.8W,L=400MM	7209240700
2092-10	FAN/DC,KD2409PTS1<->PH,260MM,SS	7209241200

No.	Cable Title	PPS
2092-1	CC/INCUBATOR CU PCB<->DOOR PCB	7209240800
2092-2	CC/INCUBATOR CU PCB<->AXIS PCB	7209240900
2092-3	CC/JUMPER<->VH,2POL	7209241100
2092-4	D259MM,24V,2X35W,SK,HEIZF.THERM.	2000000033
2092-5	CC/JUMPER<->VH,2POL	7209241100
2092-6	846X91MM,24V,2X35W,SK,HEIZFOLIE	2000000031
2092-7	CC/ENCODER,MOLEX<->JST,200MM,YELLOW	2710000189
2092-8	STEPPER-MOTOR2,AWG26,150MM,PH,NL	2710000215
2092-9	CC/LUEFTER,6.8W,L=400MM	7209240700

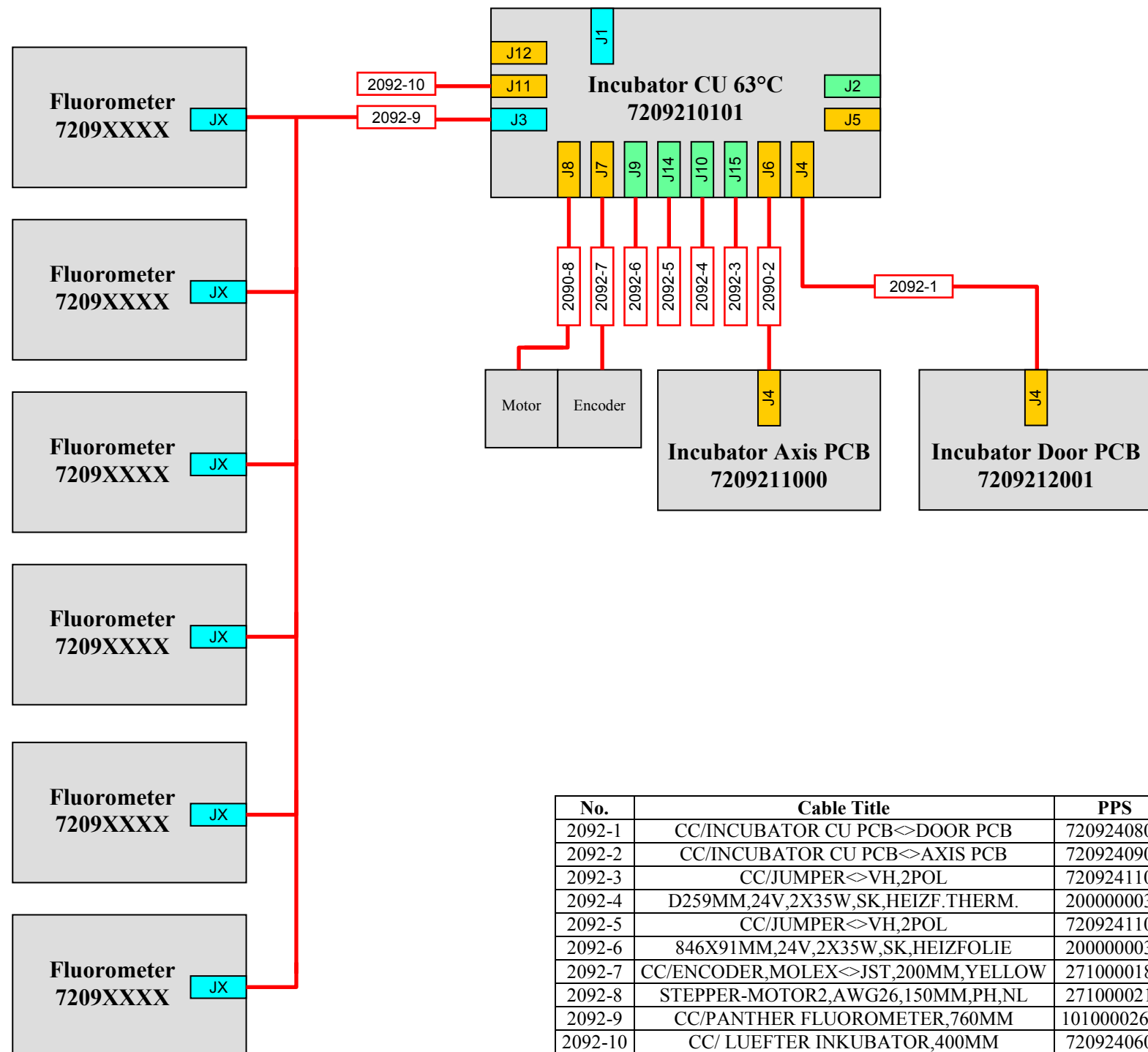

MagWash

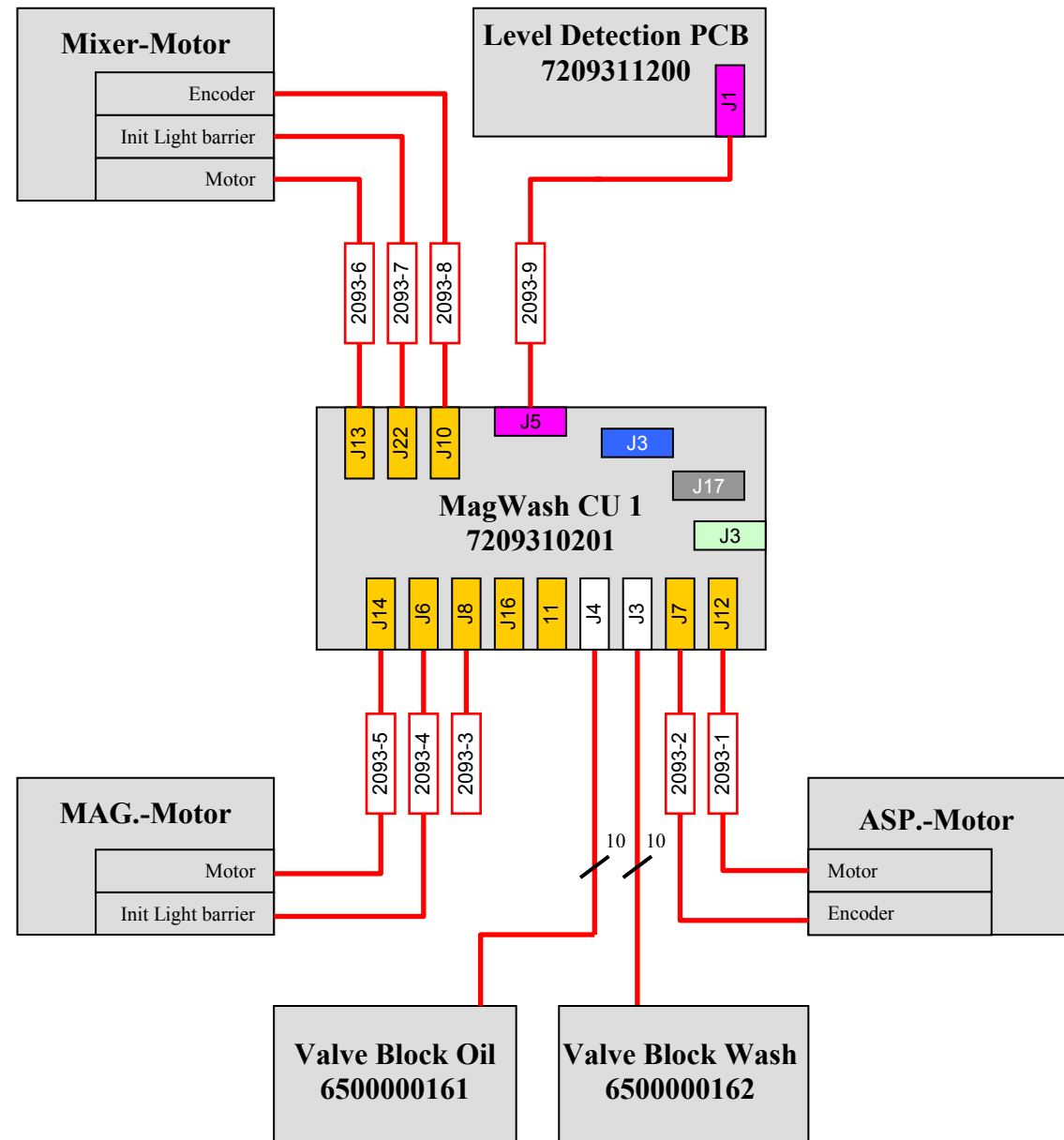

No.	Cable Title	PPS
2093-1	STEPPER-MOTOR,AWG26,110MM,RED	2710000188
2093-2	ENCODER,MOLEX<>JST,150MM,NATUR	2710000184
2093-3	ASQ10610J,440MM,JST-PH,5POL,BK,SS	6810000201
2093-4	OPB933W51,PH,320MM,NATUR	6810000169
2093-5	STEPPER-MOTOR,AWG26,230MM,NATUR	2710000187
2093-6	STEPPER-MOTOR,AWG26,100MM,YELLOW	2710000186
2093-7	OPB933W51,PH,180MM,YELLOW	6810000168
2093-8	ENCODER,MOLEX<>JST,350MM,YELLOW	2710000185
2093-9	FFC-ZIF,1X8,178MM,RM1.00,OD	2700000365

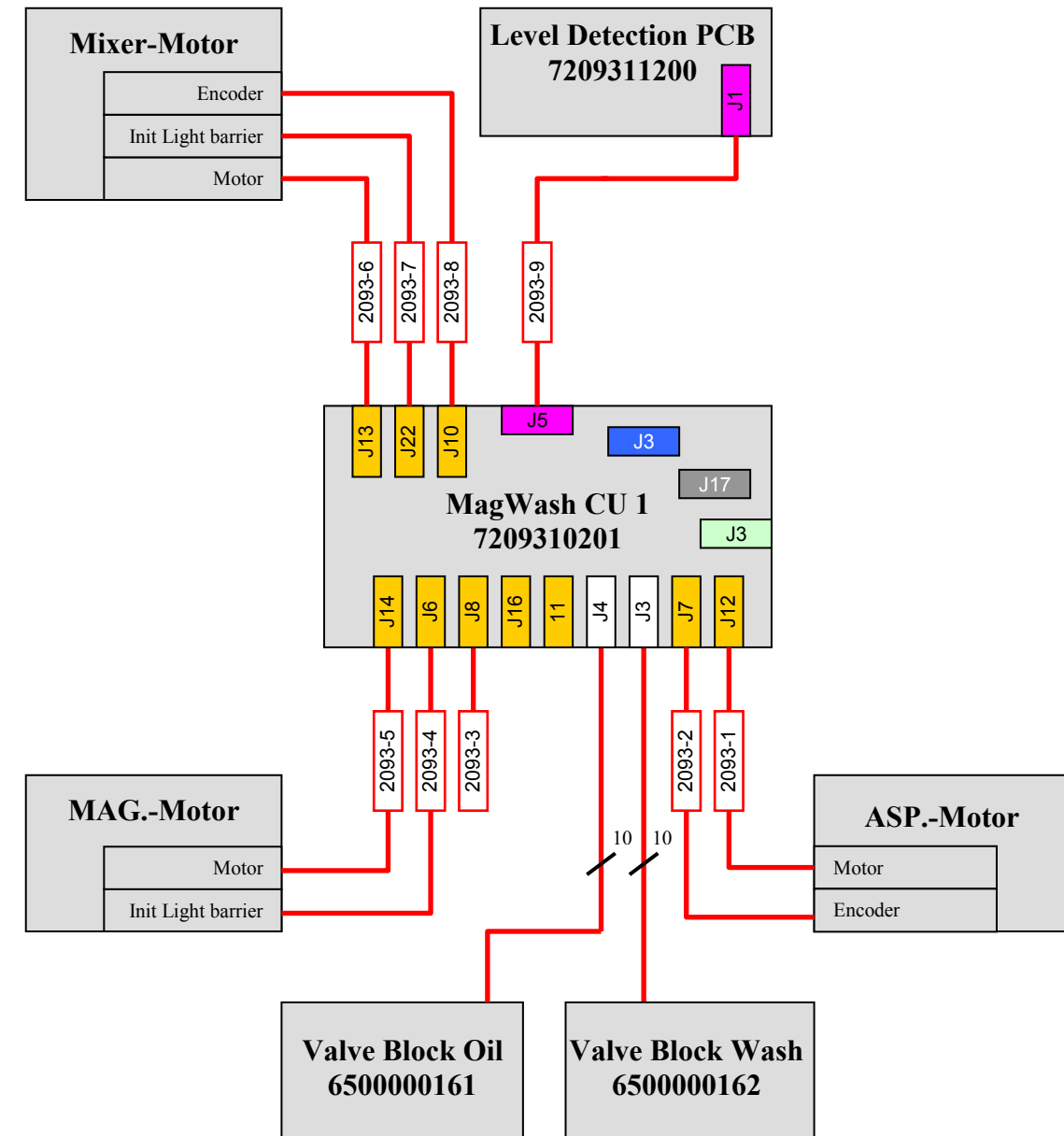

No.	Cable Title	PPS
2093-1	STEPPER-MOTOR,AWG26,110MM,RED	2710000188
2093-2	ENCODER,MOLEX<>JST,150MM,NATUR	2710000184
2093-3	ASQ10610J,440MM,JST-PH,5POL,BK,SS	6810000201
2093-4	OPB933W51,PH,320MM,NATUR	6810000169
2093-5	STEPPER-MOTOR,AWG26,230MM,NATUR	2710000187
2093-6	STEPPER-MOTOR,AWG26,100MM,YELLOW	2710000186
2093-7	OPB933W51,PH,180MM,YELLOW	6810000168
2093-8	ENCODER,MOLEX<>JST,350MM,YELLOW	2710000185
2093-9	FFC-ZIF,1X8,178MM,RM1.00,OD	2700000365

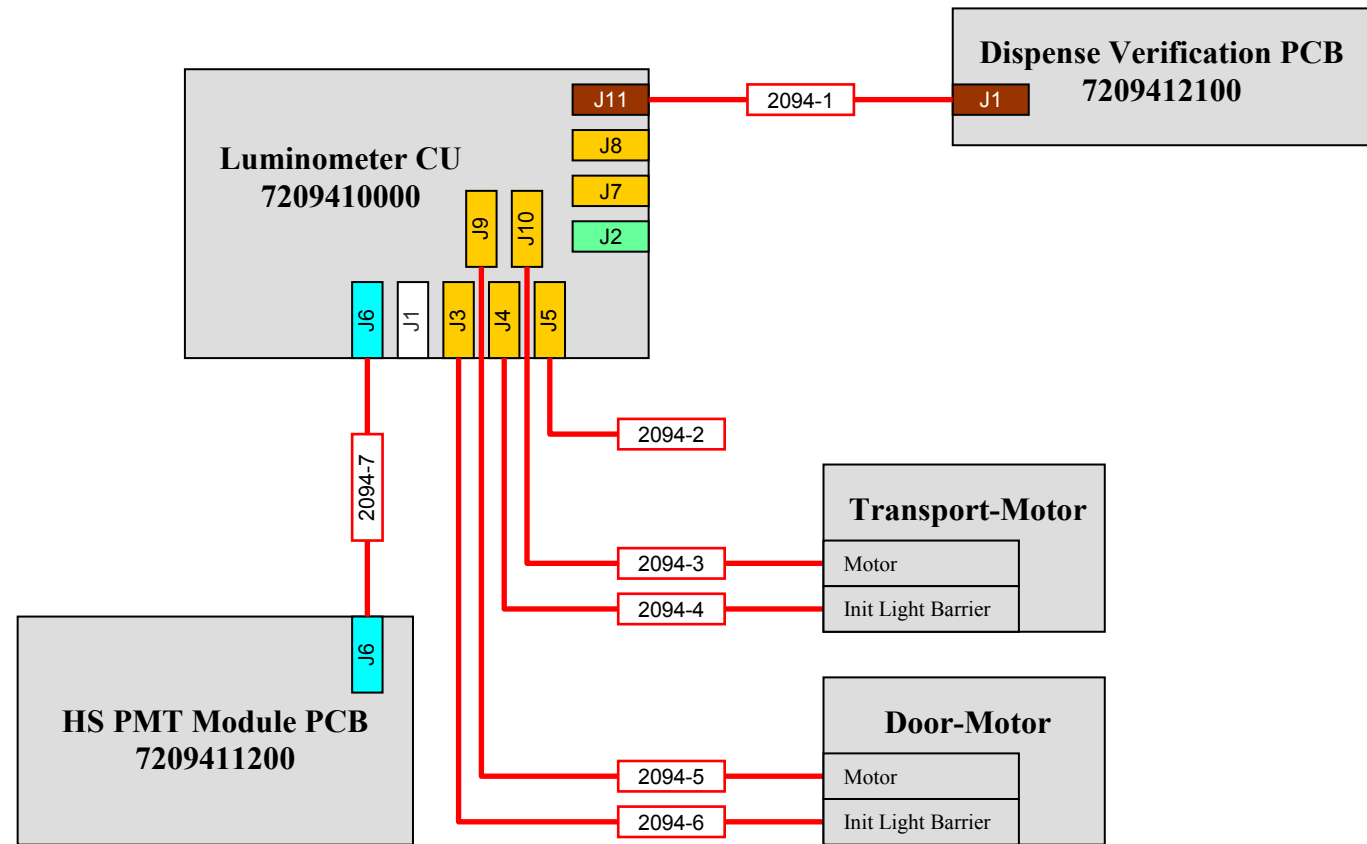

No.	Cable Title	PPS
2094-1	CC/ZH8POL<>ZH8POL,420MM	2710000231
2094-2	OPB933W51,PH,400MM,YELLOW	6810000182
2094-3	STEPPER-MOTOR2,AWG26,390MM,PH,NL	2710000210
2094-4	OPB933W51,PH,600MM,NATUR	7209440000
2094-5	STEPPER-MOTOR,AWG26,450MM,PH,RD	2710000201
2094-6	OPB933W51,PH,450MM,RD	6810000181
2094-7	CC/FLABA MAIN<>PMT,100MM	7209440200

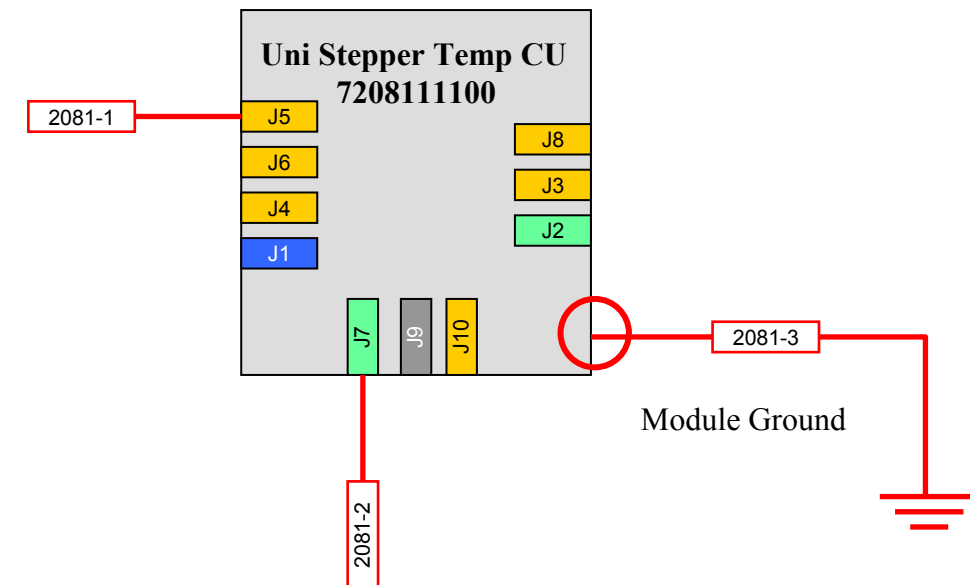

No.	Cable Title	PPS
2081-1	SE,NTC,KWM103,COAT,110MM,PH,NL,S	10100002090
2081-2	CC/CHILLER PELTIERS UEPT-42168	7208140300
2081-3	CC/MODUL<>GROUND,70MM	7208140101

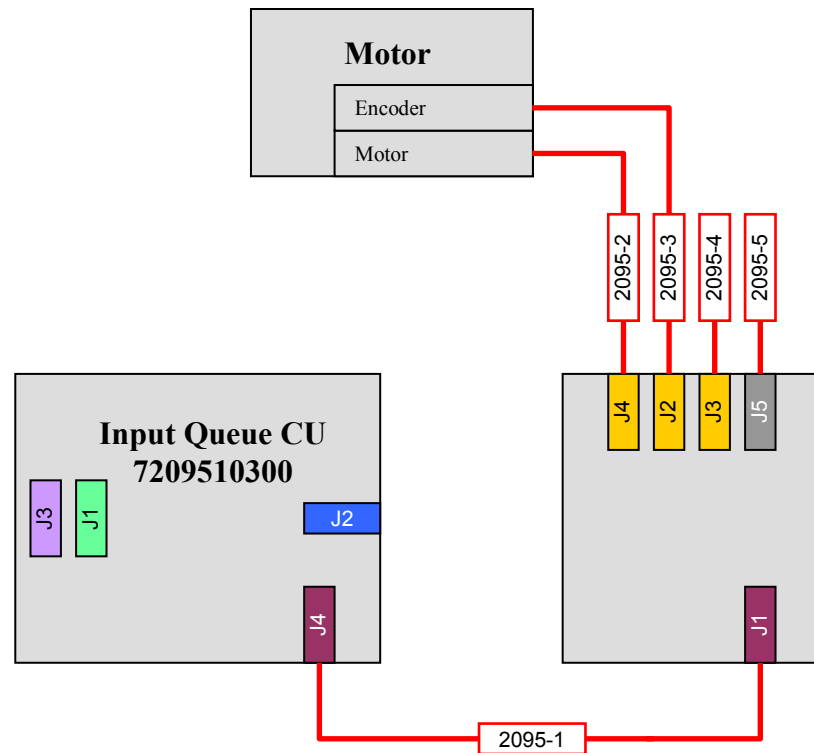

No.	Cable Title	PPS
2095-1	FFC-ZIF,1X14,470MM,RM1.00MM	2700000375
2095-2	STEPPER-MOTOR2,AWG26,300MM,PH,NL	2710000216
2095-3	CC/ENCODER,MOLEX<>JST,300MM,NL	2710000236
2095-4	OPB933W51,PH,580MM,NL	6810000174
2095-5	CC/INPUT QUEUE<>STATUS-LED	7209540200

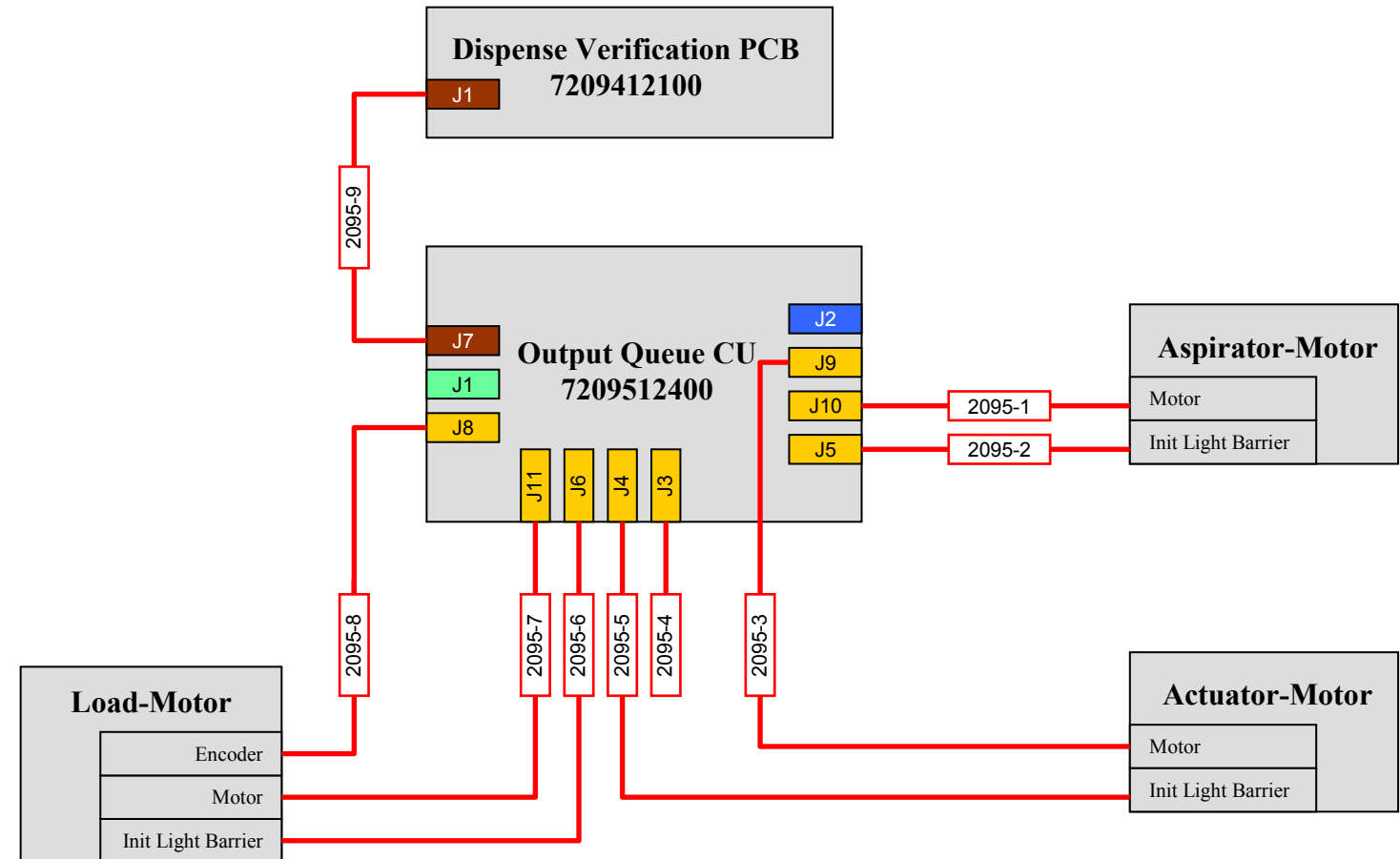

No.	Cable Title	PPS
2095-1	STEPPER-MOTOR,AWG26,150MM,PH,RD	2710000223
2095-2	OPB933W51,PH,260MM,RD	6810000173
2095-3	STEPPER-MOTOR,AWG26,150MM,PH,BK	2710000191
2095-4	OQ MTU PRESENCE SENSOR	7209540000
2095-5	OPB992T55,PH,300MM,BK	6810000238
2095-6	OPB933W51,PH,240MM,NL	6810000184
2095-7	STEPPER-MOTOR2,AWG26,150MM,PH,NL	2710000215
2095-8	CC/ENCODER,MOLEX<>JST,130MM,NL	2710000233
2095-9	CC/ZH8POL<>ZH8POL,380MM	2710000237

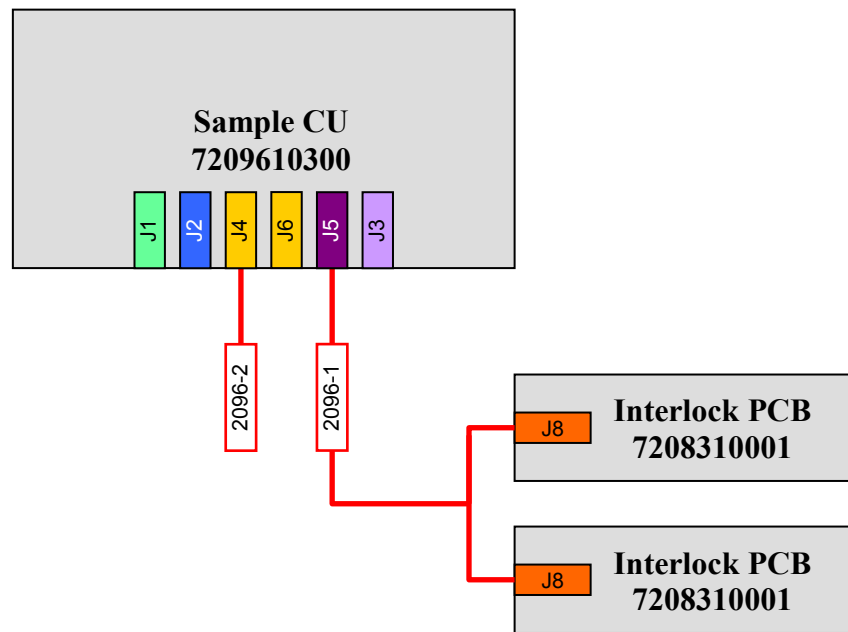

No.	Cable Title	PPS
2096-1	CC/SAMPLE CU<->INTERLOCKS	7208340000
2096-2	SE,NTC,KWM103C,COAT,200MM,PH,NL	6810000319

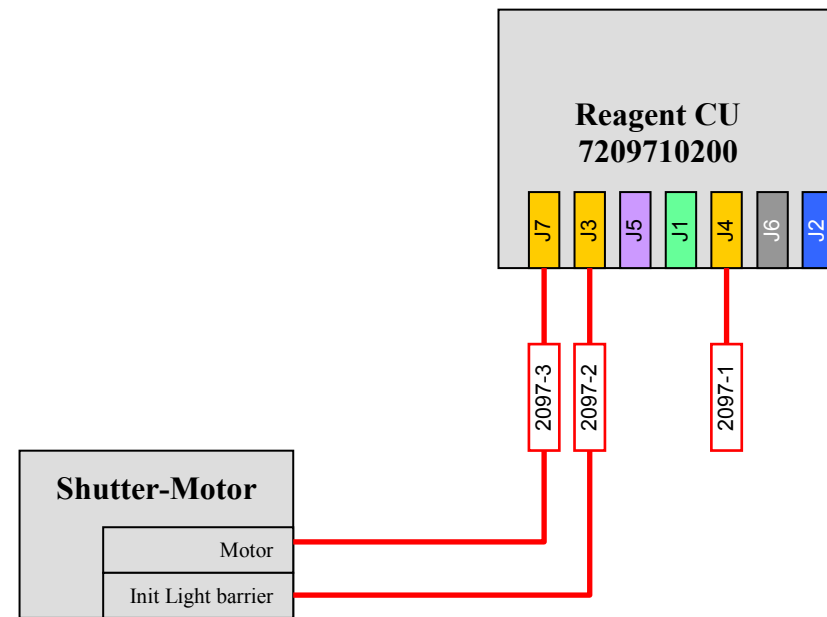

No.	Cable Title	PPS
2097-1	SE,NTC,KWM103C,COAT,160MM,PH,NL	6810000320
2097-2	OPB933W51,PH,150MM,NATUR	6810000158
2097-3	STEPPER-MOTOR,AWG26,150MM,PH,NL	2710000202

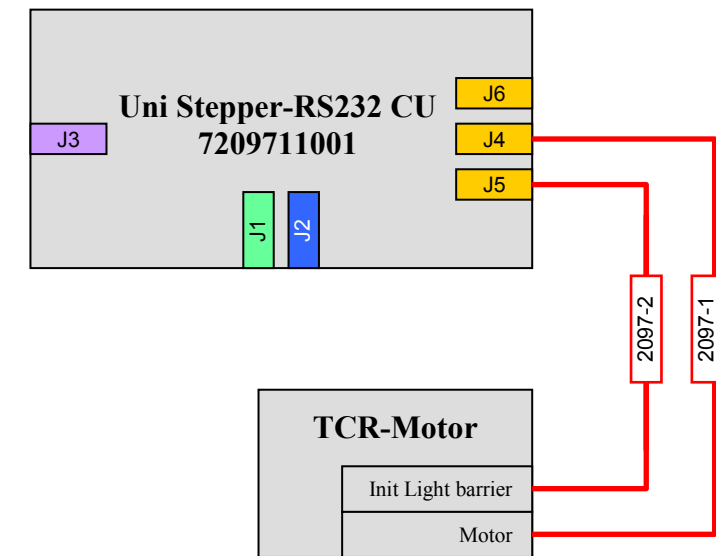

No.	Cable Title	PPS
2097-1	STEPPER-MOTOR2,AWG26,150MM,PH,NL	2710000215
2097-2	OPB912W55,PH,150MM,NATURAL	6810000171

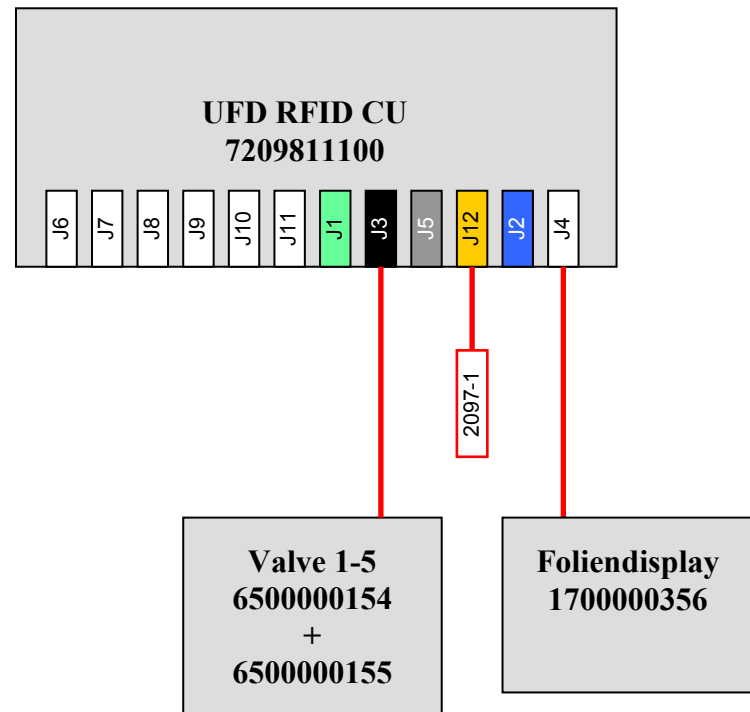

No.	Cable Title	PPS
2098-1	CC/ BLEACH LEVEL SENS <math>\leftrightarrow</math> REED 59145	7209840800

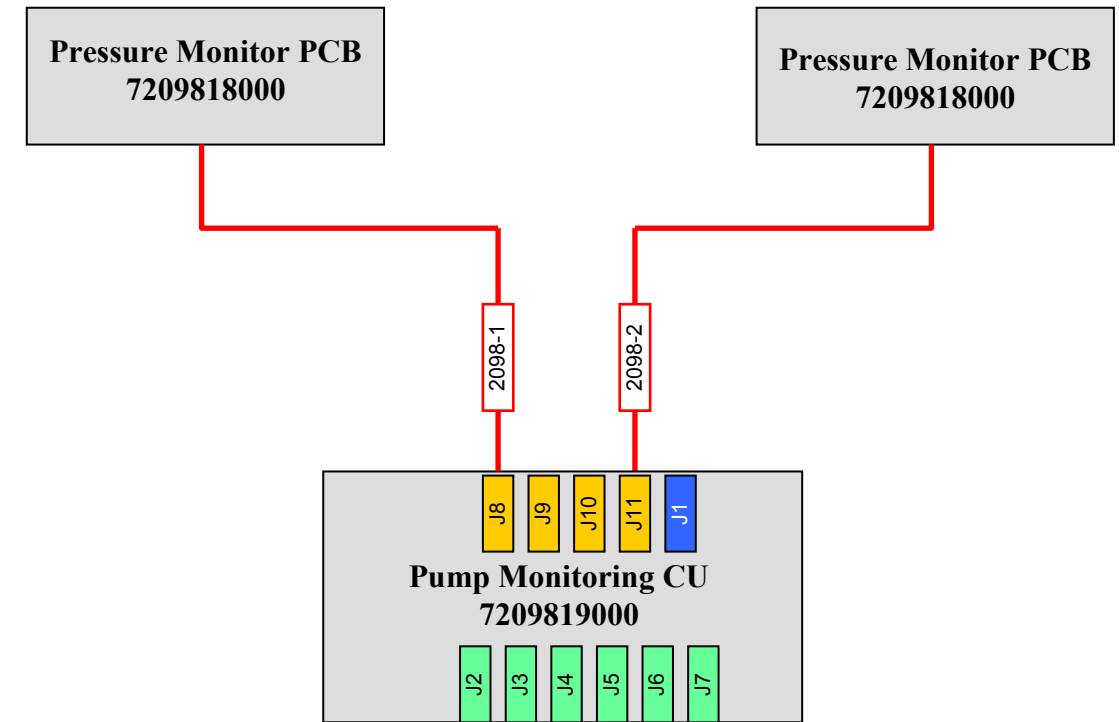

No.	Cable Title	PPS
2098-1	CC/ PUMP MON. CU PCB <math>\leftrightarrow</math> OIL. PRESS. PCB	7209840601
2098-2	CC/ PUMP MON. CU PCB <math>\leftrightarrow</math> VAC. PRESS. PCB	7209840700

left arm

right arm

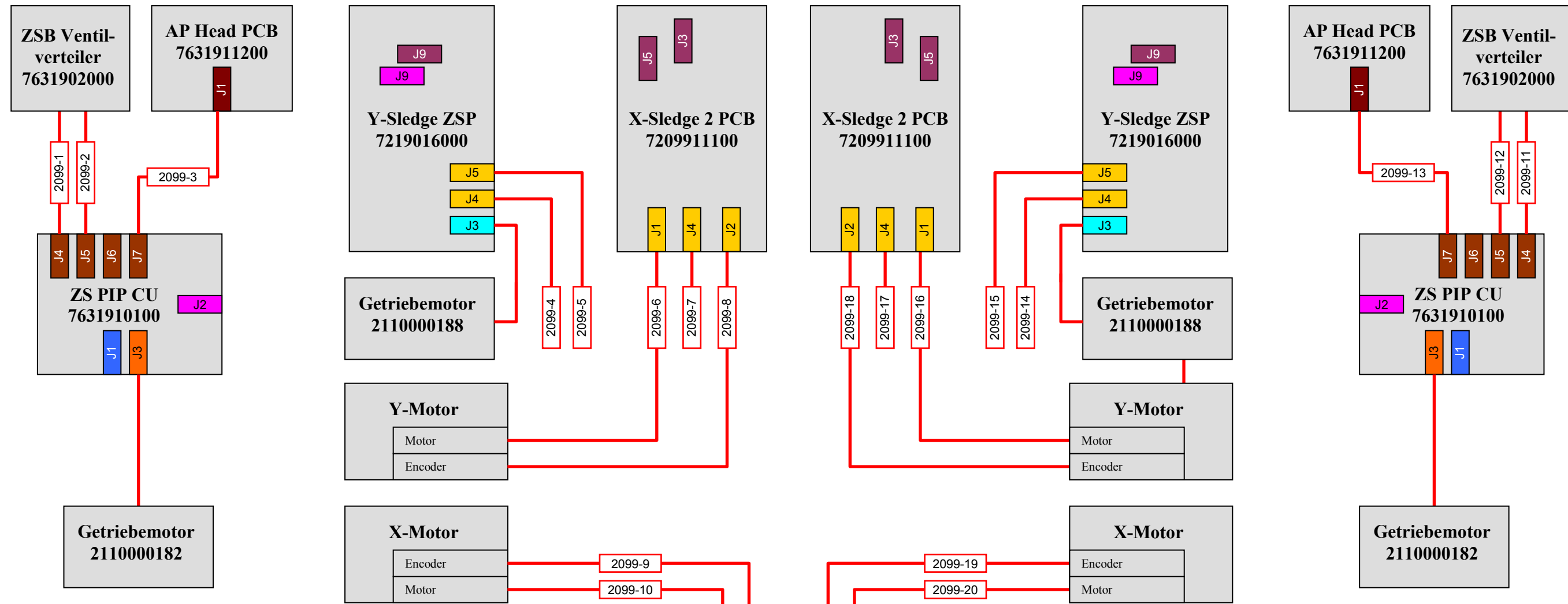

No.	Cable Title	PPS
2099-1	CC/ZS-PIP CU<->VALVE SMC 570MM	7631940301
2099-2	CC/ZS-PIP CU<->VALVE SMC 570MM	7631940301
2099-3	CC/AP-HEAD PCB<->ZS-PIP CU 575MM	7631940401
2099-4	OPB933W51,PH,240MM,NL	6810000184
2099-5	OPB992P51,PH,240MM,BK	6810000185
2099-6	STEPPER-MOTOR,AWG26,80MM,PH,NL	2710000174
2099-7	OPB912W55,PH,90MM,NATUR	6810000159
2099-8	ENCODER,MOLEX<->PH,70MM,NATUR	2710000173
2099-9	ENCODER,MOLEX<->PH,1000MM,NL	2710000175
2099-10	2657D0159,HEDR-5421-EP111,47.9W	2110000191

No.	Cable Title	PPS
2099-11	CC/ZS-PIP CU<->VALVE SMC 570MM	7631940301
2099-12	CC/ZS-PIP CU<->VALVE SMC 570MM	7631940301
2099-13	CC/AP-HEAD PCB<->ZS-PIP CU 575MM	7631940401
2099-14	OPB933W51,PH,240MM,NL	6810000184
2099-15	OPB992P51,PH,240MM,BK	6810000185
2099-16	STEPPER-MOTOR,AWG26,80MM,PH,NL	2710000174
2099-17	OPB912W55,PH,90MM,NATUR	6810000159
2099-18	ENCODER,MOLEX<->PH,70MM,NATUR	2710000173
2099-19	ENCODER,MOLEX<->PH,1000MM,NL	2710000175
2099-20	2657D0159,HEDR-5421-EP111,47.9W	2110000191

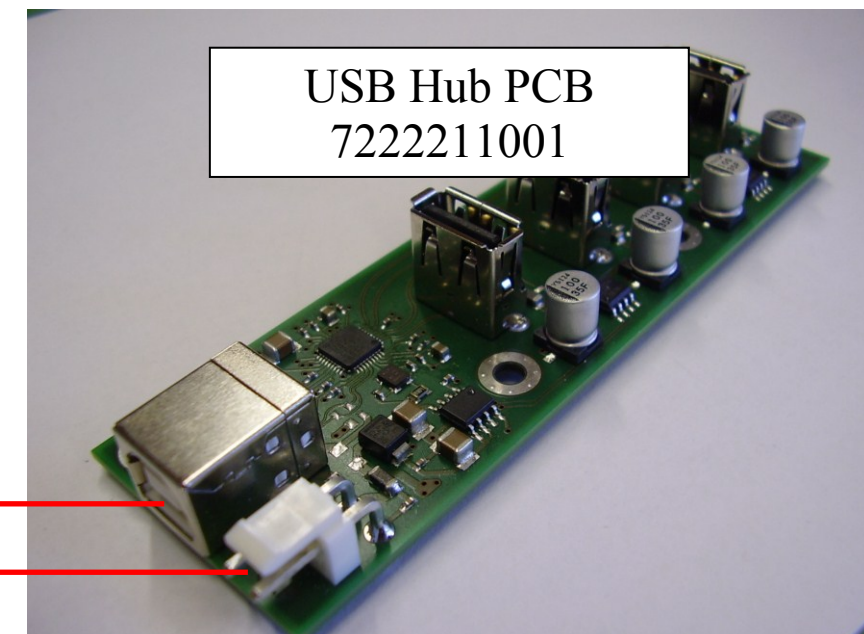
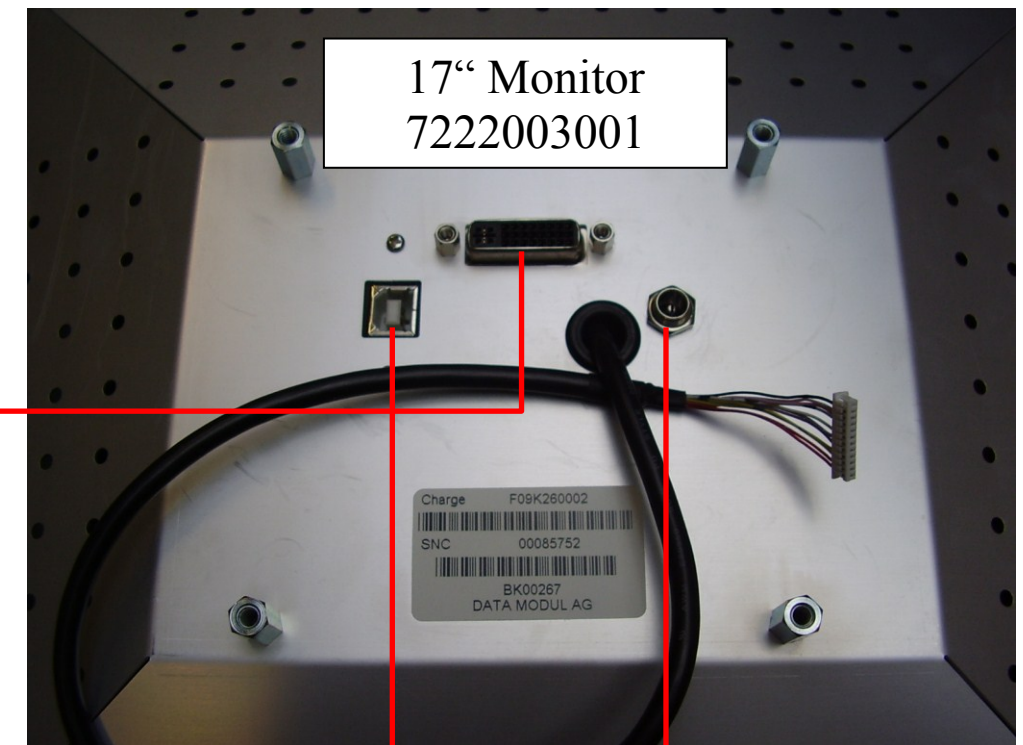
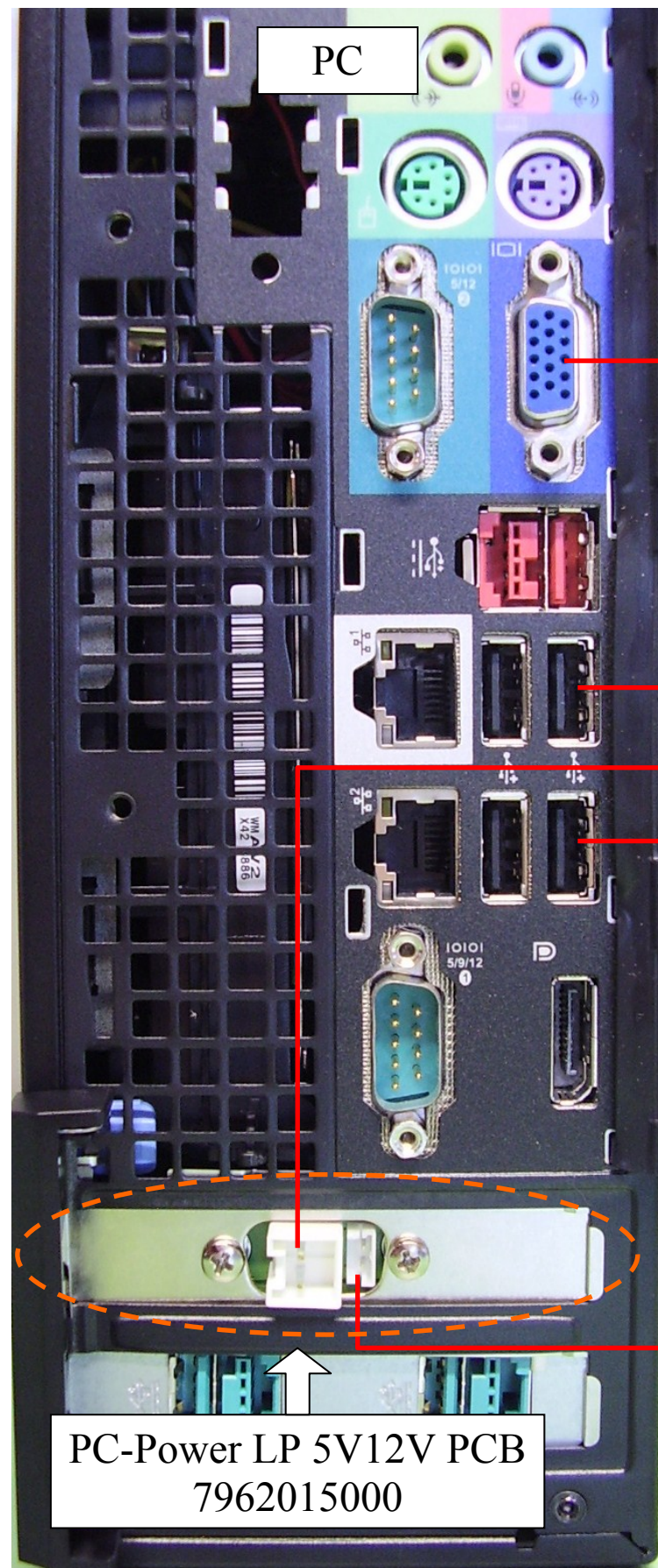

No.	Cable Title	PPS
2090-1	DVI/VGA MONITORKABEL,5M	6100000418
2090-2	USB2.0 KABEL A-B, 5.00 M,SW	6100000461
2090-3	CC/12V MONITOR-PWR,VH,2POL,370CM	7209043100
2090-4	USB2.0 KABEL A-B, 3.00 M,SW	6100000460
2090-5	CC/USB-HUB POWER CABLE,3000MM	7958040100